

Simulation of SRF Control Based Shunt Active Power Filter and Application to BLDC Drive

M. Uday Kumar¹, R. Srinivas Rao²

¹Assistant Professor, Department of Electrical and Electronics Engineering, Indo-American Institute Technical Campus, Anakapalli, Visakapatnam, (A.P), India.

²Assistant Professor, Department of Electrical & Electronics Engineering, Gokul Group of Institutions Bobbili, Vizianagaram, AP, India

Abstract : With the widespread use of harmonic generating, devices, the control of harmonic currents to maintain a high level of power quality is becoming increasingly important. An effective way for harmonic suppression is the harmonic compensation by using active power filter. This paper presents a comprehensive survey of active power filter (APF) control strategies put forward recently. It is aimed at providing a broad perspective on the status of APF control methods to researchers and application engineers dealing with harmonic suppression issues. Many control techniques have been designed, developed, and realized for active filters in recent years. This paper presents different types of Synchronous reference frame methods for real time generation of compensating current for harmonic mitigation and reactive power compensation. All the techniques are analyzed mathematically and simulation results are obtained which are being compared in terms of its compensation performance with different parameters under steady state condition. The three techniques analyzed are the Synchronous Reference Frame Theory (SRF), SRF theory without synchronizing circuit like phase lock loop (PLL) also called instantaneous current component theory and finally modified SRF theory. Simulation results are obtained under sinusoidal balanced voltage source balanced load condition. The comparison and effectiveness of all the methods is based on the theoretical analysis and simulation results obtained with MATLAB employing a three phase three wire shunt active filter test system. Finally shunt active power filter is applied to BLDC drive application. THD plots with and without APF is presented.

Keywords: component; Synchronous Reference Frame, instantaneous current component theory, Modified SRF, Active Filter, Harmonics. BLDC Drive

I. Introduction

In a modern power system, increasing of loads and non-linear equipment's have been demanding the compensation of the disturbances caused for them. These nonlinear loads may cause poor power factor and high degree of harmonics. Active Power Filter (APF) can solve problems of harmonic and reactive power simultaneously. APF's consisting of voltage-source inverters and a DC capacitor have been researched and developed for improving the power factor and stability of transmission systems. APF have the ability to adjust the amplitude of the synthesized ac voltage of the inverters by means of pulse width modulation or by control of the dc-link voltage, thus drawing either leading or lagging reactive power from the supply. APF's are an up-to-date solution to power quality problems. Shunt APF's allow the compensation of current harmonics and unbalance, together with power factor correction, and can be a much better solution than conventional approach (capacitors and passive filters). The simplest method of eliminating line current harmonics and improving the system power factor is to use passive LC filters. However, bulk passive components, series and parallel resonance and a fixed compensation characteristic are the main drawbacks of passive LC filters. In recent years, with the increase of nonlinear loads drawing nonsinusoidal currents, power quality distortion has become a serious problem in electrical power systems. As nonlinear loads, these solid-state converters draw harmonic and reactive power components of current from ac mains.

Conventionally passive L-C filters were used to reduce harmonics and capacitors were employed to improve the power factor of the ac loads. The increased severity of power quality problems and other problems associated with the passive filters such as large size and weight, higher cost, fixed compensation, and resonance problems with loads and networks have required a focus on a power electronic solution, that is, active power filters (APF) as shown in Fig.1. In recent years, many publications [26-42] have also appeared on the harmonics suppression using active power filters. Selection of a control method and proper topology of harmonic suppression, best suited to particular conditions, requires that advantages, disadvantages and limitations of these devices, which exhibit a very broad range of properties.

The control strategy for a shunt active power filter generates the reference current, that must be provided by the power filter to compensate reactive power and harmonic currents demanded by the load. This involves a set of currents in the

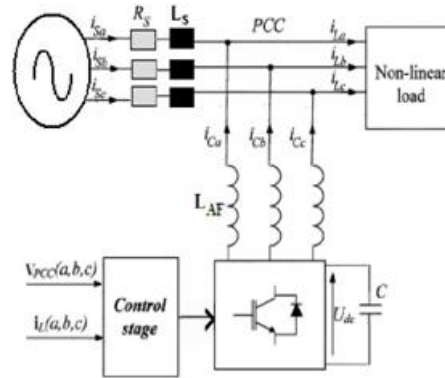

Figure. 1 Basic principal of shunt current compensation in active filter

The phase domain, which will be tracked generating the switching signals applied to the electronic converter by means of the appropriate closed-loop switching control technique such as hysteresis or deadbeat control. Several methods including instantaneous real and reactive power theory have been proposed for extracting the harmonic content [2-5]. All these methods work well under steady state, balanced and Sinusoidal conditions of supply voltage. Among all the methods presented in the literature, the Synchronous Reference Frame method (SRF) is one of the most common and probably it is the best method. It is based on the fact that harmonics change their frequency in a rotating reference frame, and so they are better isolated with high pass filters. The method presents excellent characteristics but it is a little difficult to implement. This paper presents a different modification based on the same principle and compares its performances with sinusoidal source and balanced load condition. The Modified SRF method called, in this paper, Filtered Modified Reference Frame Method (FMRF), because it uses filters and is based on the modified reference frame method [8].

II. Srf methods

Among the several methods presented in the literature, the Synchronous Reference Frame method (SRF) is one of the most common and probably it is widely used method. This section is organized as to describe succinctly the SRF methods. The three methods presented in this section with some results obtained with the above mentioned methods. The nonlinear load considered is a three-phase diode bridge rectifier.

A Synchronous Reference Theory (SRF)

In the SRF [5], the load current signals are transformed into the conventional rotating frame d-q. If theta is the transformation angle, the transformation is defined by:

$$\begin{bmatrix} x_d \\ x_q \\ x_0 \end{bmatrix} = \sqrt{\frac{2}{3}} \begin{bmatrix} \cos(\theta) & \cos\left(\theta - \frac{2\pi}{3}\right) & \cos\left(\theta - \frac{4\pi}{3}\right) \\ -\sin(\theta) & \sin\left(\theta - \frac{2\pi}{3}\right) & -\sin\left(\theta - \frac{4\pi}{3}\right) \\ \frac{1}{\sqrt{2}} & \frac{1}{\sqrt{2}} & \frac{1}{\sqrt{2}} \end{bmatrix} \begin{bmatrix} x_a \\ x_b \\ x_c \end{bmatrix}$$

Fig.2 shows the basic configuration of synchronous reference frame.

In the SRF is a time varying angle that represents the angular position of the reference frame which is rotating at constant speed in synchronism with the three phase ac voltages. In the SRF is a time varying angle that represents the angular position of the reference frame which is rotating at constant speed in synchronism with the three phase ac voltages. To implement the SRF method some kind of synchronizing system should be used. In [6] phase-locked loop (PLL) is used for the implementation of this method. In this case the speed of the reference frame is practically constant, that is, the method behaves as if the reference frame's moment of inertia is infinite. The fundamental currents of the d-q components are now dc values. The harmonics appear like ripple. Harmonic isolation of the d-q transformed signal is achieved by removing the dc offset. This is accomplished using high pass filters (HPF). In spite of a high pass filter, a low pass filter is used to obtain the reference source current in d-q coordinates.

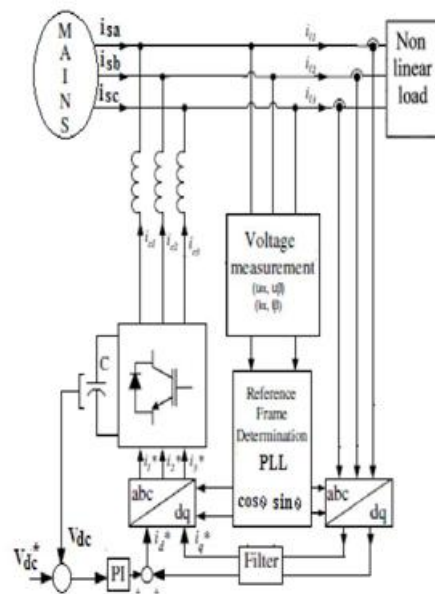

Figure. 3 Basic principle of SRF

B. Instantaneous Current Component (ia-iq) Theory : The Modified Synchronous Frame method is presented in [7]. It is called the instantaneous current component (id-iq) method. This is similar to the SRF frame method. The transformation angle is now obtained with the voltages of the ac network. The major difference is that, due to voltage harmonics and imbalance, the speed of the reference frame is no longer constant. It varies instantaneously depending of the waveform of the three phase voltage system. In this method the compensating currents are obtained from the instantaneous active and reactive current components and of the nonlinear load. In the same way, the mains voltages V(a,b,c) and the polluted currents il(a,b,c) in α - β components must be calculated as given by (2), where C is Clarke Transformation Matrix. However, the load current components are derived from a synchronous reference frame based on the Park transformation, where represents the instantaneous voltage vector angle (3).

$$\begin{bmatrix} i_{l\alpha} \\ i_{l\beta} \end{bmatrix} = [C] \begin{bmatrix} i_{l_a} \\ i_{l_b} \\ i_{l_c} \end{bmatrix}$$

$$\begin{bmatrix} i_d \\ i_q \end{bmatrix} = \begin{bmatrix} \cos \theta & \sin \theta \\ -\sin \theta & \cos \theta \end{bmatrix} \begin{bmatrix} i_{l\alpha} \\ i_{l\beta} \end{bmatrix}, \theta = \tan^{-1} \frac{v_{\beta}}{v_{\alpha}}$$

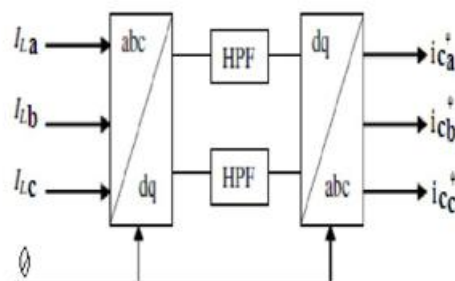

Figure.4 Principal of the synchronous reference frame method

Fig. 3 shows the block diagram SRF method. Under balanced and sinusoidal mains voltage conditions angle θ is a uniformly increasing function of time. This transformation angle is sensitive to voltage harmonics and unbalance; therefore $d\theta/dt$ may not be constant over a mains period. With transformation (2) and (3) the direct voltage component is

$$\begin{bmatrix} il_d \\ il_q \end{bmatrix} = \frac{1}{\sqrt{V_\alpha^2 + V_\beta^2}} \begin{bmatrix} V_\alpha & V_\beta \\ -V_\beta & V_\alpha \end{bmatrix} \begin{bmatrix} il_\alpha \\ il_\beta \end{bmatrix}$$

$$\begin{bmatrix} ic_\alpha \\ ic_\beta \end{bmatrix} = \frac{1}{\sqrt{V_\alpha^2 + V_\beta^2}} \begin{bmatrix} V_\alpha & -V_\beta \\ V_\beta & V_\alpha \end{bmatrix} \begin{bmatrix} ic_d \\ ic_q \end{bmatrix}$$

$$\begin{bmatrix} I_{comp,a} \\ I_{comp,b} \\ I_{comp,c} \end{bmatrix} = [C]^T \begin{bmatrix} ic_\alpha \\ ic_\beta \end{bmatrix}$$

C. Modified (id-iq) Theory

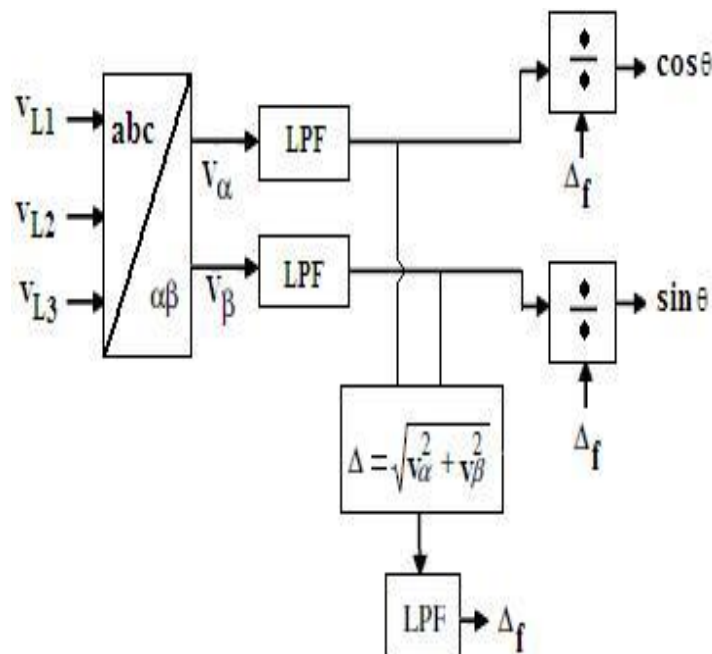

Figure.5 Principal of modified (id-iq) method

The method suggested in this section is based on the modified (id-iq) method (FMRF). The principle is the same. However there are two differences in the determination of the instantaneous position of the rotating reference frame. In spite of using the $\alpha\beta$ voltages to calculate the transformation angle, low pass filters (LPF) are used to reduce harmonics of the network signals, and consequently use on the control process approximate sinusoidal waveforms, "Fig.4". This filter is important because the method becomes more insensitive to harmonics on the mains. It will be verified also that the behaviour of the filter will be different concerning to on symmetrical and unsymmetrical conditions.

III. Mathamatical modeling of bldc

The three phase star connected BLDC motor can be described by the following four equations in bipolar mode of operation. The symbol v , i and e denote the phase to phase voltages, phase currents and phase back EMF's respectively, in three phases a, b and c. The resistance R and the inductance L are per phase values and T_e and T_L are the electrical torque and the load torque. J is the rotor inertia, B is a friction constant and ω_m is the rotor speed. The back EMF's and the electrical torque can be expressed as

$$v_{ab} = R(i_a - i_b) + L \frac{d}{dt}(i_a - i_b) + e_a - e_b \quad (1)$$

$$v_{bc} = R(i_b - i_c) + L \frac{d}{dt}(i_b - i_c) + e_b - e_c \quad (2)$$

$$v_{ca} = R(i_c - i_a) + L \frac{d}{dt}(i_c - i_a) + e_c - e_a \quad (3)$$

$$T_e = B\omega_m + j \frac{d\omega_m}{dt} + T_L \quad (4)$$

$$e_a = \frac{K_e}{2} \omega_m F(\theta_e) \quad (5)$$

$$e_b = \frac{K_e}{2} \omega_m F(\theta_e - \frac{2\pi}{3}) \quad (6)$$

$$e_c = \frac{K_e}{2} \omega_m F(\theta_e - \frac{4\pi}{3}) \quad (7)$$

$$T_e = \frac{K_t}{2} \left[F(\theta_e) i_a + F(\theta_e - \frac{2\pi}{3}) i_b + F(\theta_e - \frac{4\pi}{3}) i_c \right] \quad (8)$$

K_e and K_t are the back EMF and torque constants.

IV. Matlab/simulink modeling and simulation results

Fig. 6 shows the Matlab/Simulink model of Shunt active power filter. Here simulation is carried out for four cases. In case one APF is simulated using Synchronous Reference Theory (SRF), and case two APF is simulated in BLDC drive application.

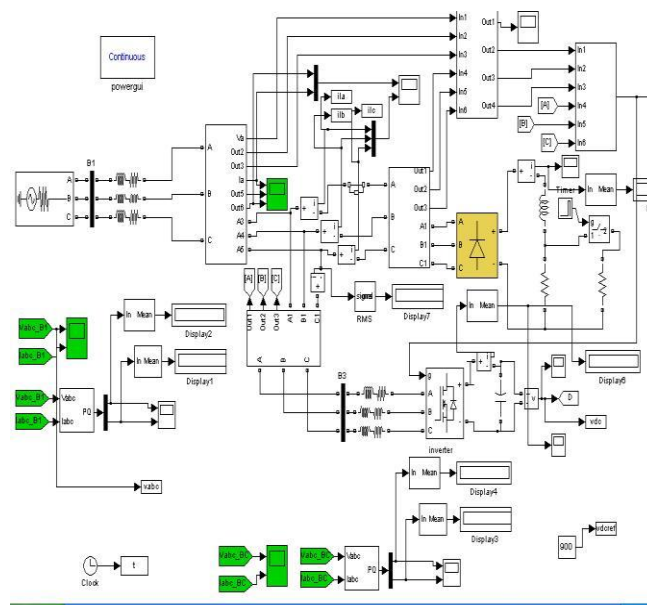

Figure.6 Matlab/Simulink Model of Shunt Active Power Filter

A Case one

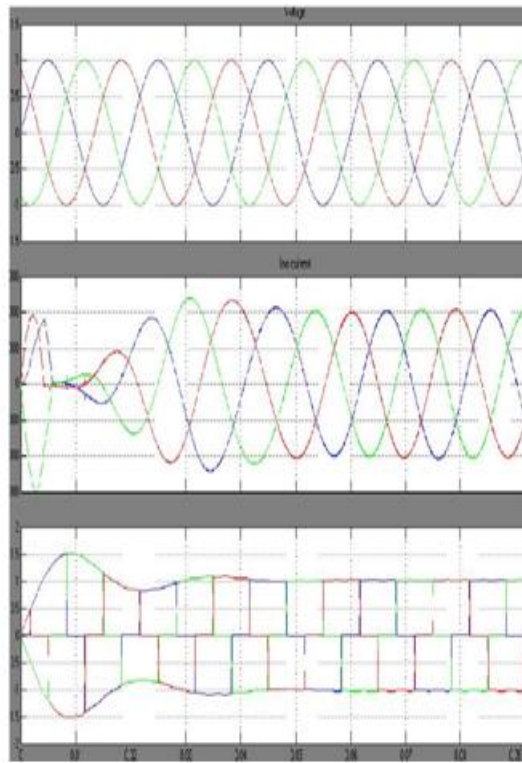

Figure. 7 Simulation results for Synchronous Reference Theory (SRF)

Fig.7 shows the simulation results for SRF theory. It shows three phase source voltage, three phase source currents and three phase non sinusoidal load currents.

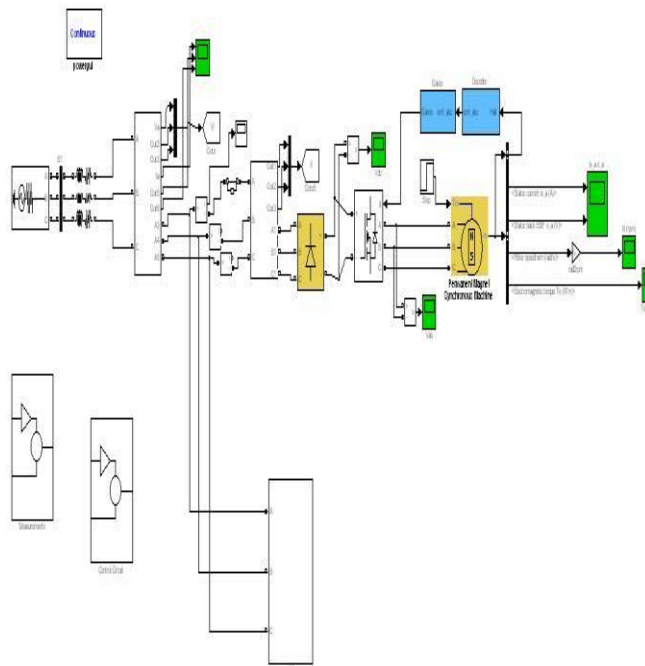

Figure. 8 Matlab/Simulink model of APF BLDC Drive

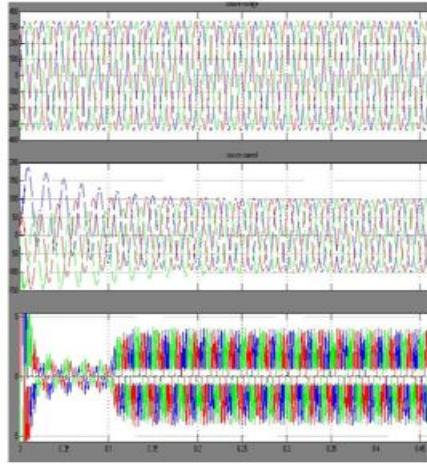

Figure. 9 Simulation results of APF BLDC drive

Fig. 9 shows the simulation results APF. It shows three phase source voltage, three phase source currents and three phase non sinusoidal load currents.

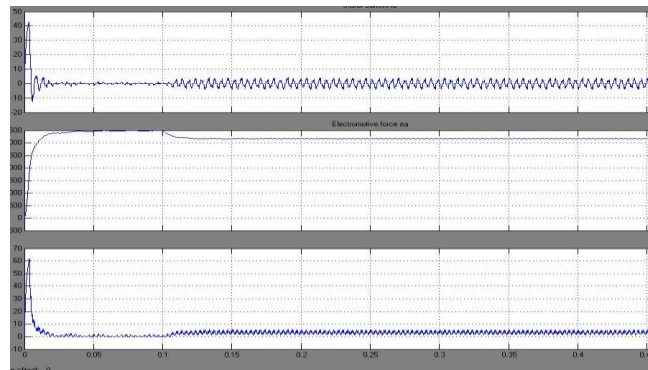

Figure. 10 Simulation results of BLDC

Fig.10 shows the simulation results of APF BLDC Drive it consists of stator currents, motor speed and electromagnetic torque.

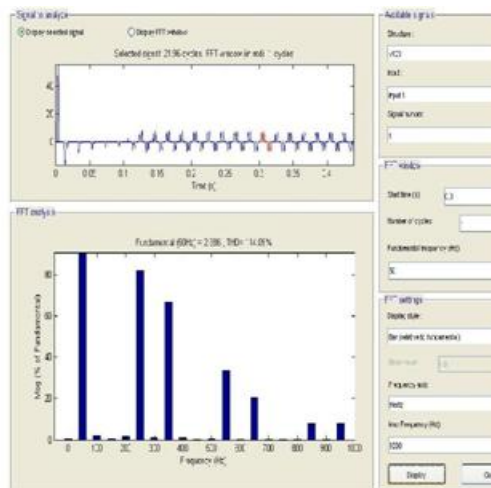

Figure. 11 FFT analysis of source current without APF

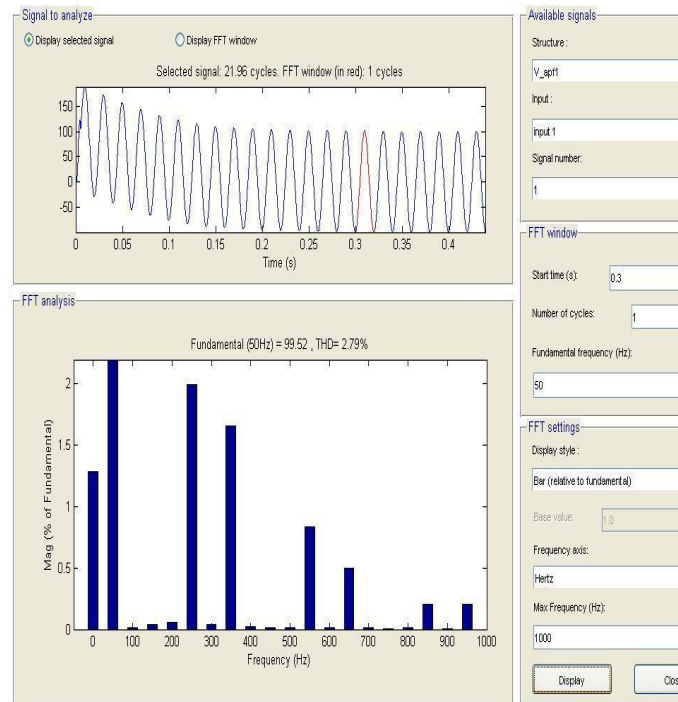

Figure. 12 FFT analysis of source current with APF

Fig.11 shows the source current without APF and harmonic spectrum. Since BLDC motor require square wave current the THD in source current without APF is very high (112%). Fig. 12 shows the source current with APF and harmonic spectrum. From this figure it is clear that with APF the THD is reduced to 2.9%.

V. Conclusion

This paper presents the compensation performance of all the different SRF techniques under sinusoidal voltage source condition as shown in table-1. Results are similar with gained source THD under IEEE 519, but under various filter type the chebyshev type filter is having superior performance compare to Butterworth filter for all methods. The Synchronous Reference Frame method is one of the most common and performing methods for detection of harmonics in active filters. An Improved Synchronous Reference Frame

Method for the control of active power filters was presented. It is called Filtered Modified Reference Frame Method (FMRF) and is based on the same principle as the Synchronous Reference Frame method. However, this new method explores the fact that the performance of the active filter to isolate harmonics depends on the speed of the system that determines the rotating reference frame, but doesn't depend on its position. So, the delay introduced by the ac voltage filters, used for the detection of the reference frame, has no influence on the detection capability of the method. Compared with other methods, this new method presents some advantages due to its simplicity. Finally a BLDC drive application is considered for simulation purpose. THD plots without APF and with APF are presented.

References

- [1] IEEE Recommended Practices and Requirements for Harmonic Control of Electrical Power systems, IEEE Standards. 519-1992,1993.
- [2] H.Akagi, "New trends in active filters for power conditioning," IEEE Industry Applications., vol. 32, No-6, pp. 1312-1322, 1996.
- [3] H. Akagi, Y. Kanazawa, and A. Nabae, "Generalized theory of the instantaneous reactive power in three-phase circuits," Proc. 1983.\)
- [4] H. Akagi, Y. Kanazawa, and A. Nabae "Instantaneous reactive power compensators comprising switching devices without energy storage components," IEEE Trans. Ind Appli., Vol. IA-20, 1984.
- [5] Bhattacharya, M. Divan, and B. Benejee, "Synchronous Reference Frame Harmonic Isolator Using Series Active Filter", 4th European Power Electronic Conference, Florence, 1991, Vol. 3, pp. 30-35.
- [6] M.J. Newman, D.N.Zmood, D.G.Holmes, "Stationary frame harmonic reference generation for active filter systems", IEEE Trans. on Ind. App., Vol. 38, No. 6, pp. 1591 – 1599, 2002.
- [7] V.Soaes,P.Verdelho,G.D.Marques," An instantaneous active reactive current component method for active filters" IEEE Trans. P ower Electronics, vol. 15, no. 4, July- 2000, pp. 660–669.
- [8] G.D.Marques, V.Fernao Pires, Mariusz Mlinowski, and Marian Kazmierkowski, "An improved synchronous Reference Method for active filters," the International conference on computer as a tool, EUROCON 2007, Warsaw, September - 2007, pp. 2564-2569.

-
- [9] V. Soares, P. Verdelho, G. D. Marques, "Active Power Filter Control Circuit Based on the Instantaneous Active and reactive Current i_d - i_q Method" Power Electronics Specialists Conference, Pesc'97 St. Louis, Missouri, June 22-27, 1997, pp- 1096-1101.
- [10] P. Verdelho, G. D. Marques, "An Active Power Filter and Unbalanced Current Compensator" IEEE Transactions on Industrial Electronics, vol. 44, N°3 June 1997, pp 321-328.
- [11] A.Cavallani and G.C.Montarani, " Compensation strategies for shunt active-filter control," IEEE Trans. Power Electron., vol. 9, no. 6, Nov. 1994, pp. 587-593.
- [12] B.Singh, K.Al-Haddad and Chandra Ambrish , " Harmonic elimination, reactive power compensation and load balancing in three phase, four wire electric distribution system supplying nonlinear loads", Electric Power System Research, Vo1.44, 1998, pp.93-100.